

# BATTLETECH™

## TURNING POINTS ORBISONIA™

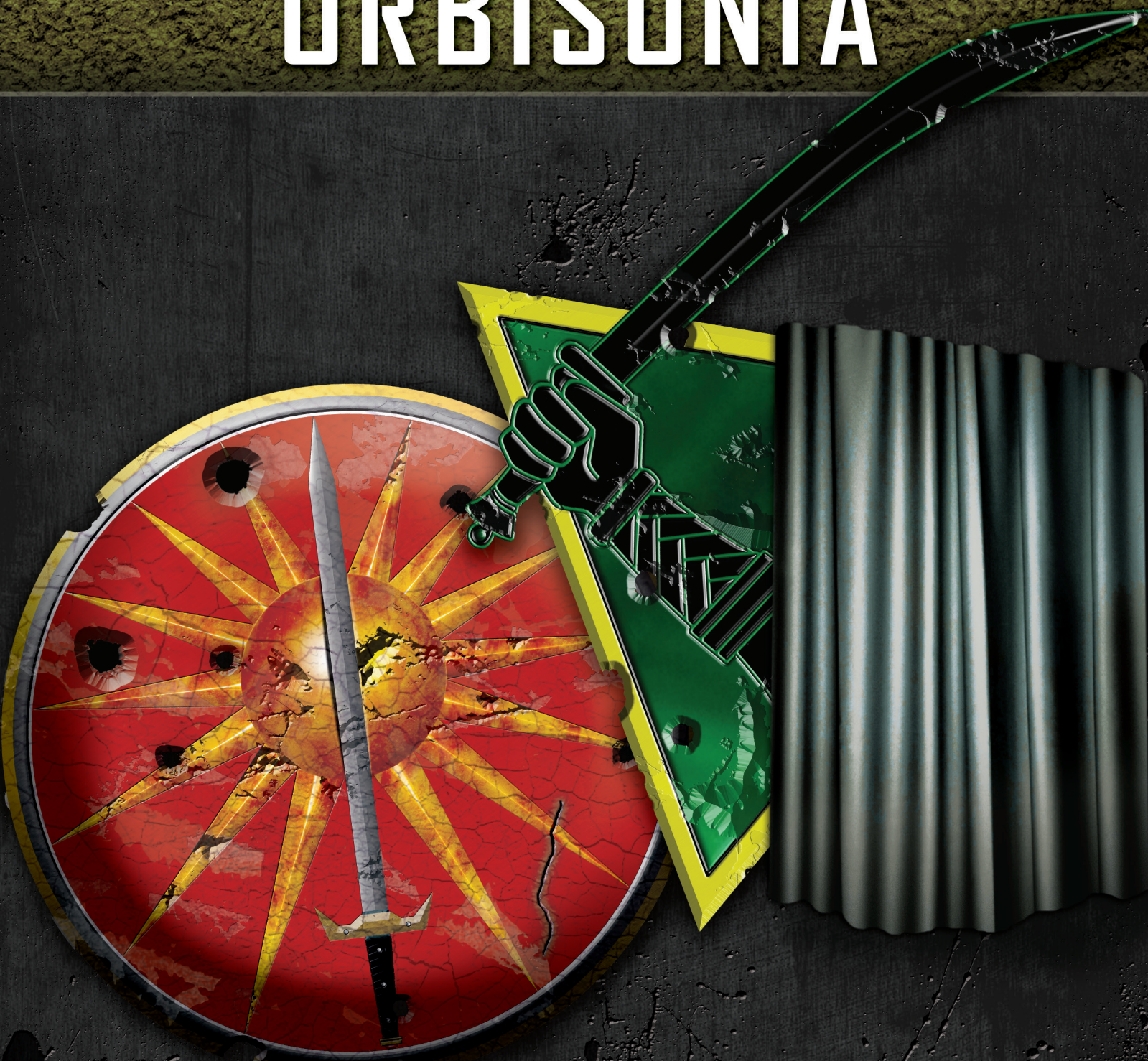





**BATTLETECH™**  
**TURNING POINTS**  
**ORBISONIA™**

Under License From



©2018 The Topps Company Inc. All rights Reserved. Turning Points: Orbisonia, BattleTech, BattleMech and 'Mech are registered trademarks and/or trademarks of The Topps Company, Inc. in the United States and/or other countries. Catalyst Game Labs and the Catalyst Game Labs logo are trademarks of InMediaRes Production, LLC.

35TP021



# A DAY IN THE LIFE OF BUFFALO JONES

**Supply Depot 124KT**  
**Orbisonia**  
**Federated Suns**  
**19 June 2828**

Buffalo Jones hated his life. It was the routine of it all. Every day the same. A MechWarrior could only take so much—he needed action! It was bad enough being talked down to by his company commander. But being in the militia and being talked down to by the *real* MechWarriors of the AFFS cycling through every couple months...that was too much. Jones was every bit as capable as most of them. They just had the good luck to be born into families that could get them into academies. Jones had to train here on Orbisonia in a simulator every weekend for six years just to make the grade as a MechWarrior at all. It wasn't fair.

Today was no different than any other Monday. Reveille, morning formation, morning assignments. As always: "Jones—Depot patrol!" With a sigh he trudged off to the 'Mech bay. Being a militia MechWarrior offered no glamour. There was no cape for his uniform, and no one wore spurs. There was no glory to be won patrolling a lousy depot. The most he could hope for would be apprehending the vandals who spray-painted what Jones had to admit were amusing caricatures of the First Prince and members of the Thane Council in compromising positions with various barnyard animals. He longed for an unlikely raid by the Capellans—or even better, pirates!—seeking to make off with the contents of the depot. Things should have changed in the last year with all the different commands passing through every few months. His head spun when he thought back to how many heroic commands had paraded through Harrison. Not that the warriors would have seen him. He was just militia, and might as well be invisible. All the transit activity increased his duties from one weekend a month to five days a week. And the monotony. He sighed.

Jones climbed the gantry ringing the outer wall of the 'Mech bay. He was in no hurry, since he was already late as the techs tried to get his 'Mech's gyro working. He clambered into his battered old *Wasp* and ran through the start-up sequence. The balky gyro glowed red on a cockpit display until he pounded the control panel a few times. A hardy clunk from under his feet heralded the light changing to green. The techs still hadn't gotten it fixed. Like himself, Jones's 'Mech was no priority. Most of the technicians had been dragooned to help refit the Avalon Hussars, so the militia had to make do. *Typical.*

Jones lowered his neurohelmet onto his shoulders and piloted the BattleMech out of the gantry. A quick sidestep, and he was out of the 'Mech bay. The depot stretched to the horizon. The rest of his lance would already be on patrol, as the territory was too vast for the unit to patrol together. Instead, they covered a series of linked routes in whichever sector was assigned to them today. Jones checked the locations of his lance. *Sector 22-Baker. Great, three clicks out.* He was going to catch hell for being late, even though it wasn't his fault. He started out.

Jones was halfway to the start of the route when an unfamiliar tone sounded over his comm system. It was on the general channel, overriding everything else. He knew there were several alert tones, but it had been so long since they'd drilled on them. He was too embarrassed to ask what the tone meant, so he ignored it.

He crossed Sector 22-Charlie into 22-Baker and checked his tactical display to see where his lance was. Strangely, they were all clustered together and moving fast. That was very unusual—they rarely saw each other outside the 'Mech bay. Maybe there was some primo new graffiti to see. He hoped this one had a mammoth or whale in it, something big to break the monotony of goats and chickens and...

The tone sounded again, for a full minute. Maybe something was wrong with his comms. He thumbed his lance frequency. "Cat Lance Actual, Cat Lance Actual. You monitor a strange tone? Over."

"Jones! That's the recall alert! Get your ass b—"

Jones had never heard Lieutenant Tigress Simpson sound so agitated. What were those sounds in the background? Loud thumps? He was nearly in visual range. He sprinted through row upon row of stacked crates, pallets, and barrels holding Blake alone knew what.

He spotted his lance. Two 'Mechs, the *Wasps* of Cheetah Garibaldi and Goldfish Janson, were down and smoking. Simpson's *Phoenix Hawk* was sprinting right toward Jones.

What in the halls of Hell was happening? Then he saw them. Silhouettes in the distance. They fired blue, coruscating bolts, blasting Simpson's 'Mech. He quickly toggled his display to a greater range. He swallowed hard. *Enemy 'Mechs, a whole helluva lot of them, closing in.* He played the selector over the red lights advancing in a perilously long skirmish line. *Marauder, Marauder, Warhammer, Marauder.* Distantly, he realized his bowels had freed themselves of a burden he didn't know was being restrained. Eyes wide, palms sweaty, mouth dry, he turned his *Wasp* about and sprinted back the way he'd come.

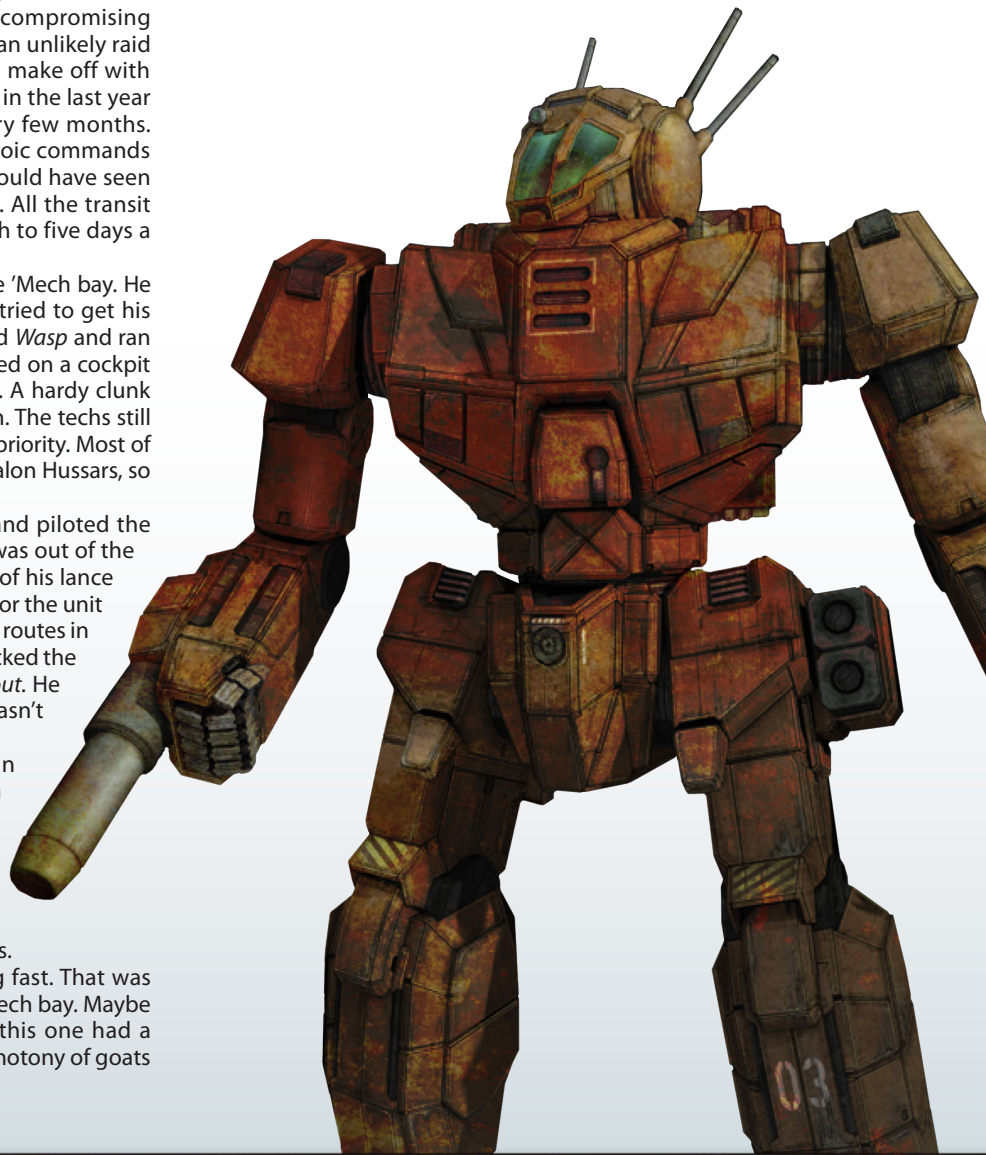

# TURNING POINTS

# ORBISONIA™

**W**elcome to the next in the series of *Turning Points* campaign products, designed to give players the opportunity to fight in some of the landmark conflicts of *BattleTech's* tumultuous history using the *Total Warfare* and *Alpha Strike* rules.

The general information contained in the **Atlas** and **Combatants** sections give players the tools needed to fight ongoing engagements in 2828, while the **Tracks** detail some of the more pivotal battles between the Capellan Confederation and Federated Suns on Orbisonia. The **Tracks** section can also be used with stand-alone games set in 2828.

The **Atlas** section presents a global overview and some quick facts about Orbisonia. Included in this section are terrain tables broken into various categories. These tables can be used as a random means to determine the mapsheets used in the tracks, or simply as a guide to the types of terrain found on the world. This section also contains a list of various additional terrain types, environments, and other rules that can be used to enhance the gameplay experience. All players should agree whether to use any or all of these features before play begins.

The **Combatants** section details the units that participated in the conflict and can be used by players who wish to add authenticity to their games. However, these forces are provided only as a guideline, and players are encouraged to use other forces at their option to attempt to rewrite history. This allows the players to pursue the tracks with different forces as they desire. Players should feel free to balance the forces in each track as they see fit, whether by Battle Value, tonnage, total number of units, or whatever else suits them.

The **Tracks** section presents the engagements which occurred on Orbisonia in 2828. For those playing the campaign, the events in each track lead into the next, with damage carrying over as applicable. Players wishing to incorporate these tracks into their *Chaos Campaign* sessions should use the Warchest Points (WP) listed in the brackets. Optional points are awarded only if the group achieves at least one Objective while using the listed option. Objective points are cumulative as they are achieved, unless otherwise noted.

## CREDITS

**Project Development:** Geoff 'Doc' Swift

**BattleTech Line Developer:** Brent Evans

*Assistant Line Developer:* Ray Arrastia

**Writing:** Geoff 'Doc' Swift

**BattleTech Line Editor:** Aaron Cahall

### Production Staff

*Cover Design:* Ray Arrastia, David Kerber

*Layout:* David Kerber

*Evolved Faction Logos Design:* Jason Knight

*Maps and Logos:* Ray Arrastia, David Kerber

**Factchecking/Playtesting:** Joshua Franklin, Mike Miller, Andreas Rudolph, Eric Salzman, Chris Wheeler

**Special Thanks:** To Ray Arrastia for giving me the reins of this product line and not thinking any less of me for wanting to write this one myself. I'd also be remiss if I didn't thank Ben Rome for conceiving and running this line for years. He gave me my start with *Historical Turning Points: Galtor* and I've been trying to get better every time. Also, I'd like to offer sincere thanks to my fellow *BattleTech* fans, for whom we do this.

## STAR LEAGUE ERA



## CLAN INVASION ERA



## JIHAD ERA



## SUCCESSION WARS ERA



## CIVIL WAR ERA



## DARK AGE ERA

### NOTE!

The last four pages of this PDF are sized for 11" x 17" paper. Please keep this in mind when printing out the document.



**ORBISONIA (2828)**  
 Elected Ruler: Leopard Lawrence  
 Star Type (Recharge Time): K4V (195 hours)  
 Position in System: 5  
 Time to Jump Point: 4.31 days  
 Number of Satellites: 1 (Wink)  
 Surface Gravity: 0.99  
 Atm. Pressure: Standard (Breathable)  
 Equatorial Temperature: 35°C (Tropical)  
 Surface Water: 56 percent  
 Recharging Station: Nadir  
 HPG Class Type: A  
 Highest Native Life: Mammals  
 Population: 1,208,244,000 (2828)  
 Socio-Industrial Levels: B-B-B-B-B

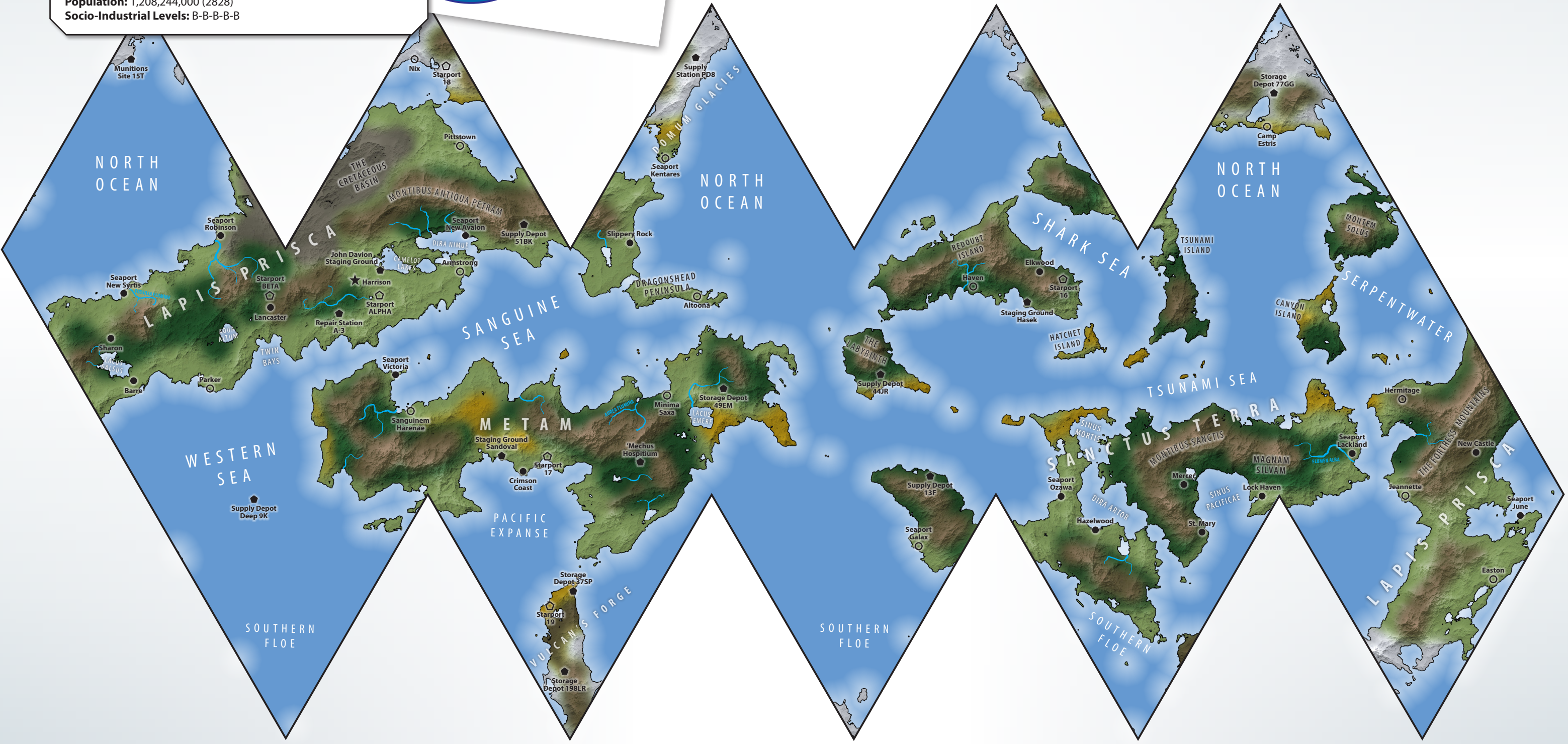
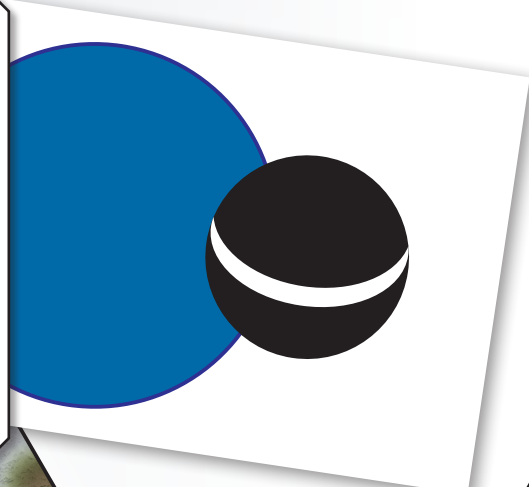



# ORBISONIA

Orbisonia has long been an important staging world for the Federated Suns' military operations against the Capellan Confederation. The world possesses abundant resources, and a large percentage of its population grew up in the shadows of the countless military staging areas dotting the world's five continents. Tourists are sometimes lured by the planet's notable geological formations, most impressive among them the Cretaceous Basin. This immense alien flatland was the floor of an ancient ocean, long ago risen to the surface during Orbisonia's once-cataclysmic tectonic upheavals. Coral formations massive enough to dwarf some DropShips form a gargantuan labyrinth thousands of hectares in size. Aside from these formations and a few other environmental preservation areas, the planet has been exploited heavily, primarily to support the AFFS. Impressive arrays of automated BattleMech repair gantries, huge storehouses of supplies, and even minor munitions factories cover vast swaths of the continental surface. Mining operations on the surface of the moon Wink, previously called Blanc, have obscured its once-white ejecta blanket. Now only the barest sliver of white shows along the satellite's equator, giving the moon its current name. The population of Orbisonia has developed an odd cultural affectation, whereby individuals' given names are those of animals. Company and militia rosters often read like the residents of a zoo rather than that of a group of persons.

## Mapsheets

The following tables represent the categories of terrain that can be found on the battlefields of Orbisonia. Players using mapsheets may either select a map from the appropriate table or randomly determine which map to use, unless otherwise specified. Note also that the various HexPacks may be used to alter the terrain of individual mapsheets as players deem appropriate. MS = *Map Set*, MSC = *Map Set Compilation*, BT = *Classic BattleTech Introductory Box Set*.

*Alpha Strike* players, or *Total Warfare* players employing terrain, should use the Terrain Table as a guideline for setting up features appropriate to the area in which their battle is taking place. Note: in *Alpha Strike* measurements are given in inches, which can be converted to centimeters by multiplying the number of inches by 2.5 (see p. 7, AS).

## Optional Rules

If all players agree, the following terrain rules may be used to add specific aspects to battles taking place on Orbisonia.

### Base Terrain Types

- Heavy Industrial Zone (see p. 65, AS)
- Rough (Ultra) (see p. 39, TO)
- Sheer Cliffs (see p. 39, TO)

## ORBISONIA MAPSHEETS TABLE

URBAN	2D6 Result	Map
	2	City (Downtown) (MS6, MSC2)
	3	CityTech Map (MS2, MSC1)
	4	City (Residential) (MS6, MSC2)
	5	City (Suburbs) (MS6, MSC2)
	6	City Street Grid/Park #1 (MS4, MSC1)
	7	City (Skyscraper) (MS6, MSC2)
	8	Military Base #1 (MS7)
	9	City (Hills/Residential) #2 (MS3, MSC1)
	10	Drop Port #1 (MS7)
	11	Drop Port #2 (MS7)
	12	Military Base #2 (MS7)

Note: May use Heavy Industrial Zone (see p. 65, AS).

WILDERNESS	2D6 Result	Map
	2	Scattered Woods (MS2, MSC1)
	3	Moonscape #1 (MS5, MSC1)
	4	Wide River (MS6, MSC2)
	5	Open Terrain #1 (MS5, MSC1)
	6	Scattered Woods (MS2, MSC2)
	7	Open Terrain #2 (MS5, MSC1)
	8	City Ruins (MS2, MSC1)
	9	Moonscape #2 (MS5, MSC1)
	10	Wide River (MS6, MSC2)
	11	BattleTech (BT, MS2, MSC1)
	12	BattleForce (MS6, MSC1)

MOONSCAPE	1D6 Result	Map
	1	Desert Hills (BT, MS2, MSC1)
	2	Moonscape #1 (MS5, MSC1)
	3	Moonscape #2 (MS5, MSC1)
	4	Scattered Woods (MS2, MSC2)
	5	Open Terrain #2 (MS5, MSC1)
6	Desert Sinkhole #2 (MS3, MSC1)	



# RANDOM ASSIGNMENT TABLES

Random Assignment Tables are meant to be used by players wishing to determine their forces randomly, or help them determine the likely equipment used by each side during the struggle for Orbisonia. Players are not required to use these tables, especially when using player-group units. To randomly assign pilot quality, see the appropriate tables in *Total Warfare* (see p. 273, TW).

To use these RATs, first determine the appropriate unit type and weight class for the force being generated from its description in the Combatants section. Then roll 2D6 on the unit type/weight class table to obtain a random unit.

Note: 'Mechs marked with an asterisk (\*) indicate a quad design.

## RANDOM ASSIGNMENT TABLES: ORBISONIA, 2828

CAPELLAN RANDOM 'MECH WEIGHT CLASSES	2d6 Result	Weight Class
	2	Assault
	3	Medium
	4	Heavy
	5	Heavy
	6	Heavy
	7	Heavy
	8	Heavy
	9	Heavy
	10	Heavy
	11	Medium
	12	Assault

MEDIUM 'MECHS	2d6 Result	Federated Suns
	2	GRF-2N Griffin [55]
	3	WVR-6R Wolverine [55]
	4	ENF-4R Enforcer [50]
	5	CN9-A Centurion [50]
	6	GRF-1N Griffin [55]
	7	PXH-1 Phoenix Hawk [45]
	8	SHD-2H Shadow Hawk [55]
	9	DV-6M Dervish [45]
	10	VL-5T Vulcan [40]
	11	SHD-2D Shadow Hawk [55]
	12	DV-6Md Dervish [55]

MEDIUM 'MECHS	2d6 Result	Capellan Confederation
	2	PXH-1b Phoenix Hawk [45]
	3	WVR-6M Wolverine [55]
	4	GRF-1N Griffin [55]
	5	CRB-20 Crab [50]
	6	PXH-1 Phoenix Hawk [45]
	7	SHD-2H Shadow Hawk [55]
	8	WVR-6R Wolverine [55]
	9	HBK-4G Hunchback [50]
	10	WTH-1 Whitworth [40]
	11	VND-1R Vindicator [45]
	12	SCP-1N Scorpion* [55]

LIGHT VEHICLES	1d6 Result	Federated Suns
	1	Galleon Light Tank [30]
	2	Harasser Missile Platform [25]
	3	Pegasus Scout Hovertank [35]
	4	J. Edgar Light Hover Tank [25]
	5	Lightning [35]
	6	Darter Scout Car [13]

HEAVY 'MECHS	2d6 Result	Federated Suns
	2	WHM-6Rb Warhammer [70]
	3	ON1-K Orion [75]
	4	RFL-3N Rifleman [60]
	5	ARC-2R Archer [70]
	6	JM6-A JagerMech [65]
	7	MAD-3R Marauder [75]
	8	TDR-5S Thunderbolt [65]
	9	WMH-6R Warhammer [70]
	10	RFL-3N Rifleman [60]
	11	QKD-4G Quickdraw [60]
	12	MAD-2R Marauder [75]

HEAVY 'MECHS	2d6 Result	Capellan Confederation
	2	WHM-7A Warhammer [70]
	3	MAD-3R Marauder [75]
	4	WHM-6L Warhammer [70]
	5	MAD-3R Marauder [75]
	6	WHM-6Rb Warhammer [70]
	7	MAD-3R Marauder [75]
	8	WHM-6R Warhammer [70]
	9	MAD-3R Marauder [75]
	10	WHM-6Rk Warhammer [70]
	11	WHM-6L Warhammer [70]
	12	MAD-2R Marauder [75]

MEDIUM VEHICLES	1d6 Result	Federated Suns
	1	T-12 Tiger Medium Tank [55]
	2	Chaparral [50]
	3	Hetzer Wheeled Assault Gun [40]
	4	Condor Hovertank [50]
	5	Zephyr [40]
	6	Condor Hovertank [50]

ASSAULT 'MECHS	2d6 Result	Federated Suns
	2	STK-3Fb Stalker [85]
	3	KGC-0000 King Crab [100]
	4	CP-10-Z Cyclops [90]
	5	BNC-3E Banshee [95]
	6	CGR-1A1 Charger [80]
	7	BLR-1G BattleMaster [85]
	8	THG-11E Thug [80]
	9	BLR-1G BattleMaster [85]
	10	HGN-732 Highlander [95]
	11	AS7-D Atlas [100]
	12	VTR-9B Victor [80]

ASSAULT 'MECHS	2d6 Result	Capellan Confederation
	2	HGN-732b Highlander [90]
	3	CP-10-Q Cyclops [90]
	4	LGB-7Q Longbow [85]
	5	BNC-3E Banshee [95]
	6	BLR-1G BattleMaster [85]
	7	STK-3F Stalker [85]
	8	STC-2C Striker [80]
	9	AWS-8Q Awesome [80]
	10	GOL-1H Goliath* [80]
	11	ZEU-5S Zeus [80]
	12	AWS-8T Awesome [80]

LIGHT 'MECHS	2d6 Result	Federated Suns
	2	LCT-1Vb Locust [20]
	3	VLK-QA Valkyrie [30]
	4	WSP-1D Wasp [20]
	5	LCT-1V Locust [20]
	6	STG-3R Stinger [20]
	7	WSP-1A Wasp [20]
	8	VLK-QA Valkyrie [30]
	9	JVN-10N Javelin [30]
	10	STG-3G Stinger [20]
	11	LCT-1E Locust [20]
	12	STG-3Gb Stinger [20]



# A CHANCELLOR'S FATE

Chancellor Ilsa Liao's plan was bold, possibly even genius. No military planner would advise a smaller, weaker, poorly-supplied military to invade a nation defended by forces that were the opposite in each respect. Ilsa ignored that common wisdom in favor of an assault small enough in scope to allow her meager military to reasonably take and hold the worlds they would strike. The prize was Chesterton, but taking that prize required secondary assaults to prevent the fearsome AFFS from counterattacking quickly. If the AFFS weren't fully occupied, the invasion would be repelled in short order. Thus, the Chancellor needed to invade worlds of lesser import than those she truly coveted. These attacks would pin those worlds' defenders in place and prevent reinforcement of her primary target, allowing her troops to gain a foothold which might enable them to repel a counterattack.

The Chancellor stripped the Free Worlds League border to assemble enough troops for her invasion. But she needed to demonstrate her faith in the plan to the rank and file, and elected to lead one of the diversionary raids herself. She would lead the assault on Orbisonia, a world unfamiliar with the tread of BattleMechs engaged in combat.

First Prince Paul Davion's forces were deep into preparations for Operation DAO, an invasion of the Confederation. However, his plans were delayed in no small part by the loss of much of the Federated Suns' merchant fleet—redeploying dozens of RCTs required more JumpShips than Davion had at his disposal. Often, portions of RCTs were moved at a time, leaving each command spread piecemeal across multiple worlds. Orbisonia was crucial to his operation, as the world had become a reliable logistics hub where troops refitted and trained for the upcoming invasion. The newly-arrived Fourteenth Avalon Hussars and Second Ceti Hussars, however, were only beginning that process. Neither command was wholly present on Orbisonia, with the other elements destined to arrive "in due time," and both units were caught completely unprepared for the arrival of two Capellan regiments.

The Red Lancers and Prefectorate Guard were reorganized at the Chancellor's explicit order, and their equipment was shipped to other commands. In its place, the regiments filled their ranks almost entirely with *Marauders* and *Warhammers*, a display of intimidation and firepower nearly unprecedented since the SLDF broke apart.

The Capellans made planetfall on 19 June 2828, after arriving at a pirate point. Their BattleMechs executed a combat drop into the northern edge of Harrison near an immense and well-stocked supply depot, placing the city itself between the invaders and the Avalon Hussars. Only the unblooded planetary militia stood in the invaders' path; the slaughter was total. The militia's light 'Mechs, light vehicles, and foot infantry mounted a laughable defense and were swept aside with no effort, leaving salvage and valuable supplies for the Capellans. While the Red Lancers moved into the city to engage the Hussars, their DropShip crews loaded up all the supplies they could.

The Fourteenth Avalon Hussars responded to the invasion with a rapid deployment through the warrens of Harrison which nearly proved their undoing. Unaware of the composition of the enemy forces, the Fourteenth's light and medium 'Mechs were overwhelmed by the Lancers' firepower. The lead elements of Marshal Nigel Sortek's regiment were obliterated, and seeing the disaster about to unfold, he gave the wise but unpalatable order to withdraw. The wide avenues of the city, often used to parade troops before deployment, provided excellent fire lanes for the enemy's heavy 'Mechs. The running fight through the city claimed half his force, but his command was saved.

While Sortek retreated, the Prefectorate Guard reboarded their DropShips and executed a speedy redeployment three hundred kilometers west. The city of Lancaster hosted Combat Command Alpha of the Second Ceti Hussars, and the Chancellor did not wish to give the Second time to mount a proper defense. The arrival of the Guard, with so many heavy 'Mechs pouring particle beams into their ranks, soon put the much lighter Ceti Hussars on the run.

The pursuit of the two defending regiments lasted well into the night, but the Chancellor could taste overwhelming victory. She contentedly retired from the cockpit in the wee hours of 20 June but was awoken shortly afterward with disastrous news. The Davion Assault Guards, perhaps the most feared command in the entire Inner Sphere, had come to Orbisonia. Unbeknownst to the Chancellor, the Guards were en route to Orbisonia before her invasion even began, and their planned use of a pirate point to make up for earlier delays allowed them to arrive on-world before the day was out. Ilsa Liao's easy victory had died—now she had to spare her troops the same fate.

She immediately ordered her DropShips to redeploy to a new location; poring over the maps, she selected the Cretaceous Basin. It was reachable from both cities where her forces were fighting, and it would force the grounded Guards and both Hussars regiments to pursue her forces through the deadly labyrinths of the Basin.

The race was on. The speedy Hussars commands, mauled though they were, harassed the invaders all the way to the basin. They slowed the Capellan retreat enough for the slower Assault Guards to close in. At one point, the Red Lancers resorted to the use of chemical weapons to break the net thrown by the Fourteenth Avalon Hussars, eliminating almost all of the Hussars' conventional forces. Rather than dissuade further pursuit, this act drove the Hussars to fanatical attacks.

The battle for Orbisonia, already a foregone conclusion, ended in the Cretaceous Basin as 23 June turned over to 24 June. While Ilsa and her personal retinue fought a rearguard action, the other regiments made good their escape. The Chancellor was not so fortunate. After rallying her remaining troops with a rousing speech, Liao held firm in a bottleneck of the coral maze. The chokepoint funneled the Davions toward them, and the Capellans tore into them with devastating combined fire. But the Assault Guards weathered the storm and engaged the Capellans at point-blank range; none of the rearguard survived and Ilsa Liao became the first Chancellor to be killed in combat. She was succeeded by her daughter Laurelli, who abandoned the bold invasion. Instead, the Confederation was forced onto the defensive for the rest of the Second Succession War, as the Federated Suns adjusted their strategy after the unexpected invasion.



# COMMANDERS

## ILSA LIAO

**Rank:** Chancellor (Capellan Confederation)

**Born:** 2783 (45 in 2828)

Ilsa Liao was the granddaughter of Chancellor Barbara Liao. Ilsa's mother died in childbirth and her father, Balthazar, was among the forces killed during the disastrous invasion of Calloway VI in 2787. The orphaned heir was taken in by her grandmother, but when Barbara died in 2795, Ilsa was still too young to ascend the throne. Instead, Prefect Sandol Quinn of the Tikonov Commonality was installed as regent until Ilsa turned 18. While Quinn spent his time on the frontlines of the First Succession War, Ilsa learned to navigate Sian's politics and developed a personal distaste for combat during her brief command of a lance of the Red Lancers. After taking the throne, Ilsa's initial hopes for forging peace eventually gave way to an unforgiving desire to restore the Confederation. The aftermath of the First Succession War left her nation all but crippled, and her effort to leverage enemy POWs in exchange for materiel necessary to rebuild the CCAF failed miserably. After she began executing the highest-ranking prisoners, First Prince Paul Davion's tune changed, and the Chancellor extorted considerable amounts of military equipment from the Suns in exchange for those prisoners still living. She won her victory, but earned further enmity from the hated Davions.

When the Second Succession War broke out, Ilsa aimed to reclaim her nation's lost Chesterton Commonality worlds from the Federated Suns, despite the poor state of the CCAF compared to the militaries of her neighbors. Rather than wait for an invasion to come to her, she launched one of her own. It was a strategically brilliant move that would prove to be her undoing. Although she caught the AFFS by surprise, she ran straight into the teeth of the forces planning to invade her own realm. Her rallying cry on the Cretaceous Basin of Orbisonia inspired generations of Capellan troops, but most would likely have preferred her continued leadership to that of her daughter and son, as the Confederation suffered greatly after Ilsa's death.

**Skill:** Veteran (3)

**BattleMech:** *Marauder* MAD-2R

**Alpha Strike Data:** Sniper, BM, Size: 3, MV: 8", TMM: 1, S/M/L: 4/4/3, OV0, A/S 7/6, Specials CASE, PV 40 (48)

**Special Pilot Abilities:** Lucky (2) (see p. 54, *Alpha Strike Companion* or p. 77, *Campaign Operations*) and Multi-Tasker (see p. 55, *ASC* or p. 78, *CO*).

## NIGEL SORTEK

**Rank:** Marshal (Federated Suns)

**Born:** 2778 (50 in 2828)

Nigel Sortek rose quickly through the AFFS ranks during the First Succession War, due as much to combat losses as to his skills both as a MechWarrior and an administrator. Despite his strong desire to remain in the Davion Brigade of Guards, he could not pass up the opportunity to command an RCT. When such a post became available with the Fourteenth Avalon Hussars, the Albion Military Academy graduate pushed hard for the promotion. While Sortek was not the youngest marshal in the AFFS at the time, he became the youngest to ever command the Fourteenth.

Nigel quickly realized the poor situation he had inherited; the Fourteenth was a lackluster command compared to the Davion Guards. Discipline was lacking, morale was low, and the Transportation and Resupply Command kept the Fourteenth far down the priority list. He immediately set about instilling a proper training regimen, and pushed his troops through the rigors of simulated combat as though the enemy were scratching at the borders.

His efforts were beginning to bear fruit when preparations for Operation DAO began and the Fourteenth was transferred from Breed to Orbisonia for refit and staging. Only the unit's ground forces had arrived on-world when the Capellans invaded. Sortek trusted his methods, but wasn't yet sure he could trust his warriors. He didn't really have any choice in the matter.

**Skill:** Elite (2)

**BattleMech:** *Marauder* MAD-3R

**Alpha Strike Data:** BM, Size: 3, MV: 8", TMM: 1, S/M/L: 2/3/3, OV1, A/S 6/6, Specials N/A, PV 35 (49)

**Special Pilot Abilities:** Iron Will (see p. 54, *ASC* or p. 76, *CO*) and Marksman (see p. 54, *ASC* or p. 77, *CO*).

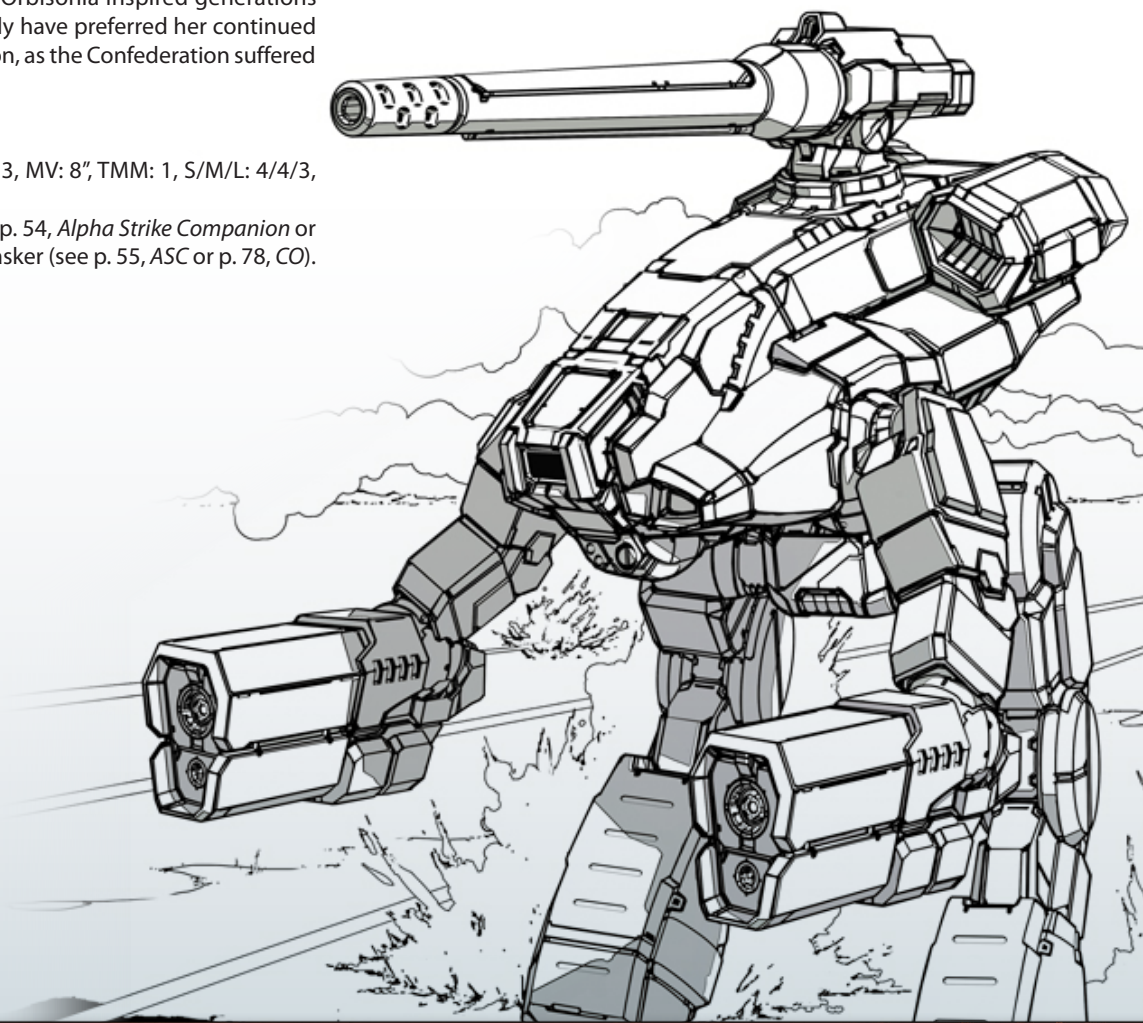



# COMBATANTS

This section lists the combat units active on Orbisonia. The Experience Level indicates which column to consult when using the *Random Skills Table* (see p. 273, *TW*) for the combatants.

The *RAT* entry determines which Random Assignment Tables (see *Orbisonia*, 2828 *RAT*, pg. 6) to consult if randomly determining a force. If not using a player-defined unit from a campaign, use the *Unit Generation* rules (see p. 264, *TW*). Capellan players roll on the Capellan Random 'Mech Weight Classes table (p. 6) rather than the Random Weight-Class Tables in *TW*. For the faction tables to roll from, locate the *RAT* entry for each combatant.

If not using the Orbisonia, 2828 *RAT*, choose a variant appropriate for the faction involved to give a specific flavor to the forces in play. Variants dating to 2828 or earlier are recommended.

**RAT sources:** *First Succession War (1SW)*, *Second Succession War (2SW)*

*Unit Abilities* are special game rules that apply to that unit in combat. These rules are optional, and all players should agree to their use before gameplay begins. The *Notes* section gives in-universe details on the unit to help give players a "feel" for the command during the battles on Orbisonia.

*Special Command Abilities* can be found on p. 44, *ASC* or p. 83, *CO* unless otherwise noted.

## Prefectorate Guard [Capellan Confederation]

**CO:** Colonel Sable Ruetiger

**RAT:** Capellan Confederation

**Notes:** The Prefectorate Guard was formed to safeguard the Capellan Prefecture and its families. It has seen much less combat since its inception in 2532 than the rest of the CCAF, due to the requirement that a majority vote of the Prefecture Council approve its deployment elsewhere. Chancellor Ilsa Liao, a member of this council, swayed the other voters to support sending the Guard into the Federated Suns as part of Operation CELT. Their approval was contingent upon her promise to accompany the command, after filling its ranks with *Marauders* and *Warhammers*. It was hoped that the overwhelming firepower provided would overcome the command's long-standing defensive specialization.

**Experience Level:** Regular (4)

**Unit Composition:** 1 heavy 'Mech regiment, 1 medium aerospace fighter squadron, 1 Foot infantry company

**Special Rules:** During combat on Orbisonia in 2828, at least two lances of every company must be composed entirely of *Marauders* and *Warhammers*. The overall ratio of *Marauders* to *Warhammers* should be 5 to 1. The other lances roll on the Random Capellan 'Mech Weight Class Table, p. 6.

**Special Command Abilities:** Tactical Specialization (Defense).



## Red Lancers [Capellan Confederation]

**CO:** Colonel Nikolai Yurchenko

**RAT:** Capellan Confederation

**Notes:** The Red Lancers were formed in 2355 as the Second Hexare Lancers. The unit was renamed the Red Lancers after crushing the rebellious Merik's Grenadiers in 2452 and appointed as the Chancellor's bodyguard, a role it has filled ever since. The Lancers are most often deployed to Capella or Sian

in this capacity, but are also frequently sent to respond to Davion or Marik incursions into Capellan space. They are among the CCAF's elite commands, a requirement for safeguarding the Chancellor.

**Experience Level:** Elite (2)

**Unit Composition:** 1 heavy 'Mech regiment

**Special Rules:** During combat on Orbisonia in 2828, at least two lances of every company must be composed entirely of *Marauders* and *Warhammers*. The overall ratio of *Marauders* to *Warhammers* should be 5 to 1. The other lances roll on the Random Capellan 'Mech Weight Class Table, p. 6.

**Special Command Abilities:** Banking Initiative, Off-Map Movement, Zone of Control.



## Chancellor's Guard [Capellan Confederation]

**CO:** Captain Leticia Sanchez

**RAT:** Capellan Confederation

**Notes:** This detachment of the Red Lancers accompanies the Chancellor of the Capellan Confederation. They have access to any equipment in the Confederation, but when active with other forces, they match their BattleMechs to the most common in those units. On Orbisonia in 2828, the company consisted of ten *Marauders* and two *Warhammers*. Every one of the *Marauders* was the same variant as the Chancellor's, and matched hers in colors, equipment, and condition.

**Experience Level:** Elite (2)

**Unit Composition:** 1 heavy 'Mech company

**Special Rules:** When two or more of the unit's 'Mechs of the same variant are adjacent to one another, the entire group (including the Chancellor, if applicable) blends together to confuse incoming fire. Opposing units add an additional +2 target movement modifier even if the Guard units remain stationary. In addition, an adjacent unit may take the damage in the location rolled instead of the unit that was actually targeted. If using the *Special Pilot Ability* rules (see *Campaign Operations*, p. 70, or *Alpha Strike Companion*, p. 49), each MechWarrior may choose any SPAs in accordance with their Experience Level.

**Special Command Abilities:** Esprit de Corps (see p. 89, *Combat Manual: Mercenaries*), Focus (Sniper), Focus (Marksman).

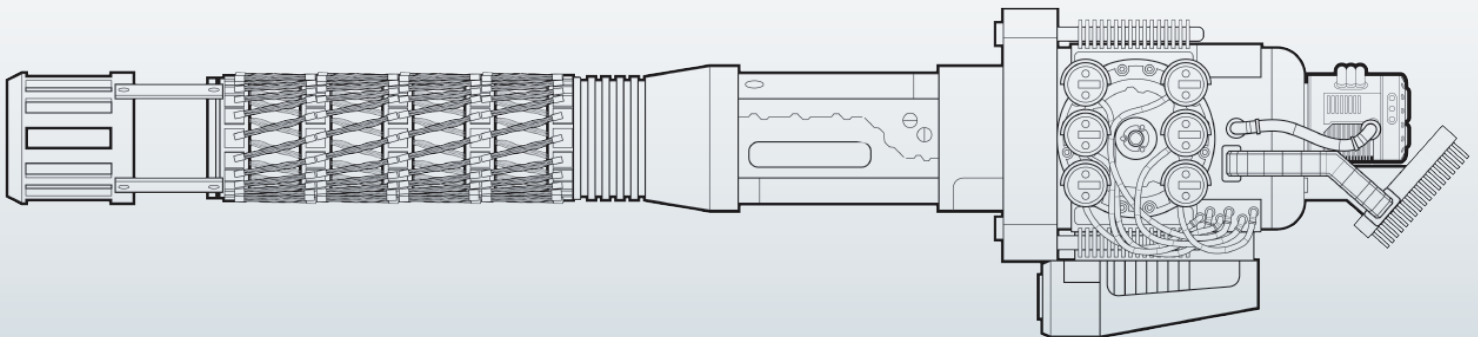

## Orbisonia Planetary Militia [Federated Suns]

**CO:** Colonel Salamander Tykeer

**RAT:** Federated Suns

**Notes:** The Orbisonia Planetary Militia is a typical militia command composed of local troops commanded by AFFS retirees. The militia spends its time protecting supply dumps from trespassers and smugglers; direct response to enemy aggression falls to any AFFS regiments present and awaiting deployment.

**Experience Level:** Regular (4)

**Unit Composition:** 1 light 'Mech company, 1 light vehicle company, 1 foot infantry battalion

**Special Command Abilities:** Regional Specialization (Orbisonia) (see p. 85, *Combat Manual: Kurita*).

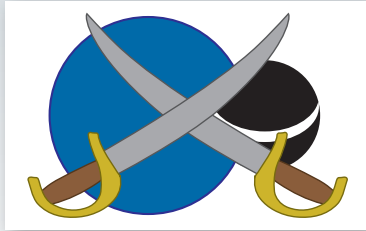

## Fourteenth Avalon Hussars [Federated Suns]

**CO:** Marshal Nigel Sortek

**RAT:** Federated Suns

**Notes:** The Fourteenth pursues its operations with such reckless abandon that the command is always understrength due to combat losses. In addition, the Fourteenth was critically short of operational jump jets when the Capellans invaded, a supply issue exacerbated by the planning of Operation DAO, which shifted commands to new staging areas before their supplies arrived. Finally, the Hussars aerospace assets had yet to join the BattleMechs on Orbisonia when the Confederation's invasion force landed.

**Experience Level:** Veteran (3)

**Unit Composition:** 2 medium 'Mech battalions, 2 medium vehicle battalions, 2 infantry regiments

**Special Rules:** During combat on Orbisonia in 2828, reduce all Jumping Movement by half (rounding down).

**Special Command Abilities:** Hit and Run (see p. 85, *CM: Kurita*), Rapid Strike (see p. 85, *CM: Kurita*).

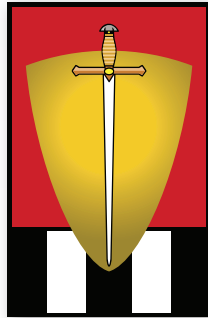

## Second Ceti Hussars [Federated Suns]

**CO:** Colonel Jezebel Pryce

**RAT:** Federated Suns

**Notes:** The Ceti Hussars were formed as a combined-arms command integrated below the regimental level. The RCT consists of a trio of combat commands, each built around a 'Mech battalion. Each command also includes two vehicle battalions and two infantry regiments. The Hussars' fighter wing and artillery battalion are independent subcommands that attach to any of the three combat commands as needed.

Combat Command Alpha is a flanking force which outmaneuvers the enemy as the rest of the RCT closes in, preventing any solid defense from materializing. Combat Command Bravo is composed of heavy and assault units. Combat Command Charlie provides fire support and presses the enemy in any conditions.

**Experience Level:** Veteran (3)

**Unit Composition:** 3 Combat Commands, Heavy Aerospace Fighter wing, Artillery battalion

**Special Rules:** During combat on Orbisonia in 2828, reduce all Jumping Movement by half (rounding down); in addition, only Combat Command Alpha, without aerospace or artillery support, is available for play.



**Special Command Abilities:** Combat Command A: Off-Map Movement; Combat Command B: Brawlers; Combat Command C: Tactical Specialization (Attack); Aerospace: Tactical Specialization (Dogfighting); Artillery: Adjusting Fire.

## Davion Assault Guards [Federated Suns]

**CO:** Marshal Cameron Baxter

**RAT:** Federated Suns

**Notes:** The Assault Guards RCT is built around a four-battalion reinforced 'Mech regiment, supported by fighter wings, vehicle regiments, and infantry regiments. Each subcommand is more than capable of standing alone against any enemy. The Crushers are the heaviest unit in the AFFS, and surprise enemies by extracting greater speed from their massive units than opponents expect. The Crushers assemble each unit type into groups of similar weapon ranges; each unit type supports the others but remains separate in battle. Subcommands use concentrated fire to pound powerful enemies into dust, with entire companies sometimes firing on a single enemy unit to demonstrate what fate awaits the rest. The artillery regiment has two battalions of Long Toms to bottle up retreating enemies for destruction by the advancing 'Mechs. The infantry units secure fallen enemy 'Mechs—often after putting them down themselves.

**Experience Level:** Veteran (3)

**Unit Composition:** Reinforced Assault 'Mech regiment, 3 Heavy Aerospace Fighter wings, 4 Assault Vehicle regiments, 5 Infantry regiments (2 Foot, 2 Motorized, 1 Jump), Artillery regiment

**Special Rules:** Only the BattleMech regiment was present for combat on Orbisonia in 2828.

**Special Command Abilities:** Focus (Speed Demon), Tactical Experts (Combined Fire), Ground Support Specialists, Overrun Combat.





# OVERMATCHED

## SITUATION

Supply Depot 124KT  
Orbisonia  
Federated Suns  
19 June 2828

The untested Orbisonia Planetary Militia spent its days patrolling supply depots until the Chancellor of the Capellan Confederation came a'calling with two regiments. The militia's troops aren't exactly cowards, but their light 'Mechs, light tanks, and infantry were no match for an advancing wall of heavy 'Mechs. Retreat was the only option.

## GAME SETUP

*Recommended Terrain:* Urban, Industrial

Arrange the playing surface to include primarily urban and/or industrial terrain, or select two mapsheets from the Urban column of the Orbisonia Terrain Table (p. 5) and place them with their long edges touching. The Defender places 2D6+10 single hex supply counters (see *Special Rules*). The Defender chooses a home edge. The opposite edge is the Attacker's home edge.

## Attacker

*Recommended Forces:* Prefectorate Guard

The Attacker's force is 100 percent of the Defender. The Attacker enters via the Defender's home edge and the two adjacent edges.

## Defender

*Recommended Forces:* Orbisonia Planetary Militia

The Defenders are a combined-arms force of BattleMechs, vehicles, and infantry. The Defender may use up to the entire militia force (see unit description, p. 10). The Defender deploys within 6" or 3 hexes of the Attacker's home edge.

## WARCHEST

**Track Cost:** 500

### Optional Bonuses

- +500 **Can't You Count?** Double the size of the opposing force.
- +500 **Precious Supplies.** The supplies cannot be risked; units may not fire weapons into or through any supply counter.

## OBJECTIVES

1. **Run! (Defender Only)** Exit units off the home edge. [100 per unit]
2. **Hunt! (Attacker Only)** Prevent enemy units from escaping. [100 per unit destroyed/crippled]

## SPECIAL RULES

The following rules are in effect for this track:

### Forced Withdrawal

Both sides are operating under *Forced Withdrawal* (see p. 258, *TW* or p. 27, *AS*).

## Supplies

The supplies include non-hazardous materiel along with munitions and other volatiles. Every time a weapon is fired into or through a supply counter, the player controlling the firing unit rolls 2D6. On an 8+, the supplies are destroyed in an explosion, inflicting 10 damage within 2" or 1 hex of the supply counter. (If using *Total Warfare* rules, apply 20 damage in 5-point groups.) Only make this roll the first time a counter is fired through; if it does not explode the first time, it never will. Remove any supply counter that explodes. Supply counters may not be moved through by any unit save infantry.

## AFTERMATH

The Planetary Militia panicked when attacked by so many *Marauders* and *Warhammers*. They tried to escape the Capellans, but while the Prefectorate Guard drove into the depot, the Red Lancers flanked the militia and exterminated them before they could flee.

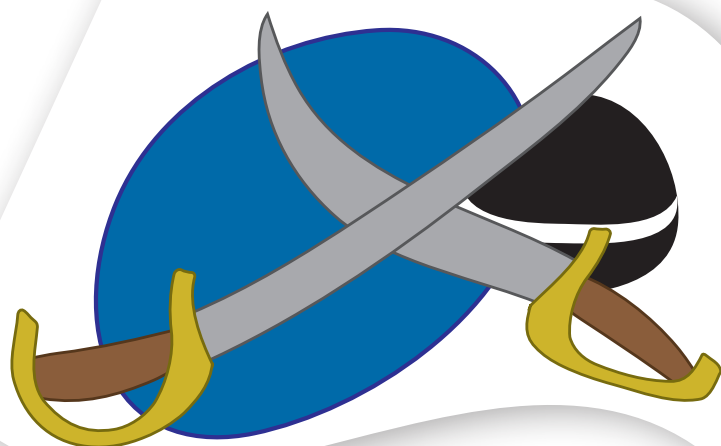

# PAINT THE TOWN RED

## SITUATION

Harrison  
Orbisonia  
Federated Suns  
19 June 2828

From the supply depot, the Red Lancers pushed into the capital city, where the Fourteenth Avalon Hussars met them in the streets. On paper, the Hussars' light and medium 'Mechs were no match for the heavy 'Mechs of the Red Lancers. But the Hussars were made of sterner stuff than the militia—they threw caution to the wind and themselves into the fray.

## GAME SETUP

*Recommended Terrain:* Urban, Industrial

Arrange the playing surface to produce congested urban terrain, or select two mapsheets from the Urban column of the Orbisonia Terrain Table (p. 5) and place them with their long edges touching. The playing area should include a road network lined with buildings of various sizes and types. The Attacker chooses a home edge. The Defender's home edge is the opposite edge.

### Attacker

*Recommended Forces:* Fourteenth Avalon Hussars

The Attacker's force is 100 percent of the Defender and is limited to BattleMechs only for this track. The Attacker's units enter via their home edge or either adjacent edge (within 6 hexes or 12" of home edge) on Turn 1.

### Defender

*Recommended Forces:* Red Lancers

The Defender chooses any number of full lances for this battle. The Defender's units are deployed along their home edge prior to play.

## WARCHEST

**Track Cost:** 500

### Optional Bonuses

**+500 We Can Take Them!**

Double the size of the enemy force.

**+500 Limit Collateral Damage.** Damage to buildings should be avoided (see *Special Rules*). **[Reduce by 50 for each building destroyed by that player's units]**

## OBJECTIVES

- 1. Overwhelm.** Exit units off enemy's home edge. **[50 per unit]**
- 2. Exterminate.** Destroy (not cripple or force to withdraw) enemy units. **[100 per unit]**

## SPECIAL RULES

The following rules are in effect for this track:

### Forced Withdrawal

Both sides are operating under *Forced Withdrawal* (see p. 258, *TW* or p. 27, *AS*).

### Buildings

Harrison's buildings are especially fragile. Any weapons fire that misses its target will automatically strike the next building in the line of fire, continuing along the straight line between the attacker and the target. Apply the full damage for the weapon to the building.

## AFTERMATH

The Avalon Hussars bravely engaged the Red Lancers, but their bravery was not enough to overcome the invaders' superior firepower. Rather than lose his entire command, Marshal Nigel Sortek ordered his troops to retreat. They rejoined their conventional forces on the south side of Harrison and withdrew in good order. Half the Hussars' BattleMechs were lost in the action, while the Red Lancers took hardly any casualties at all. The battle for Orbisonia seemed like a walk in the park for the invaders.

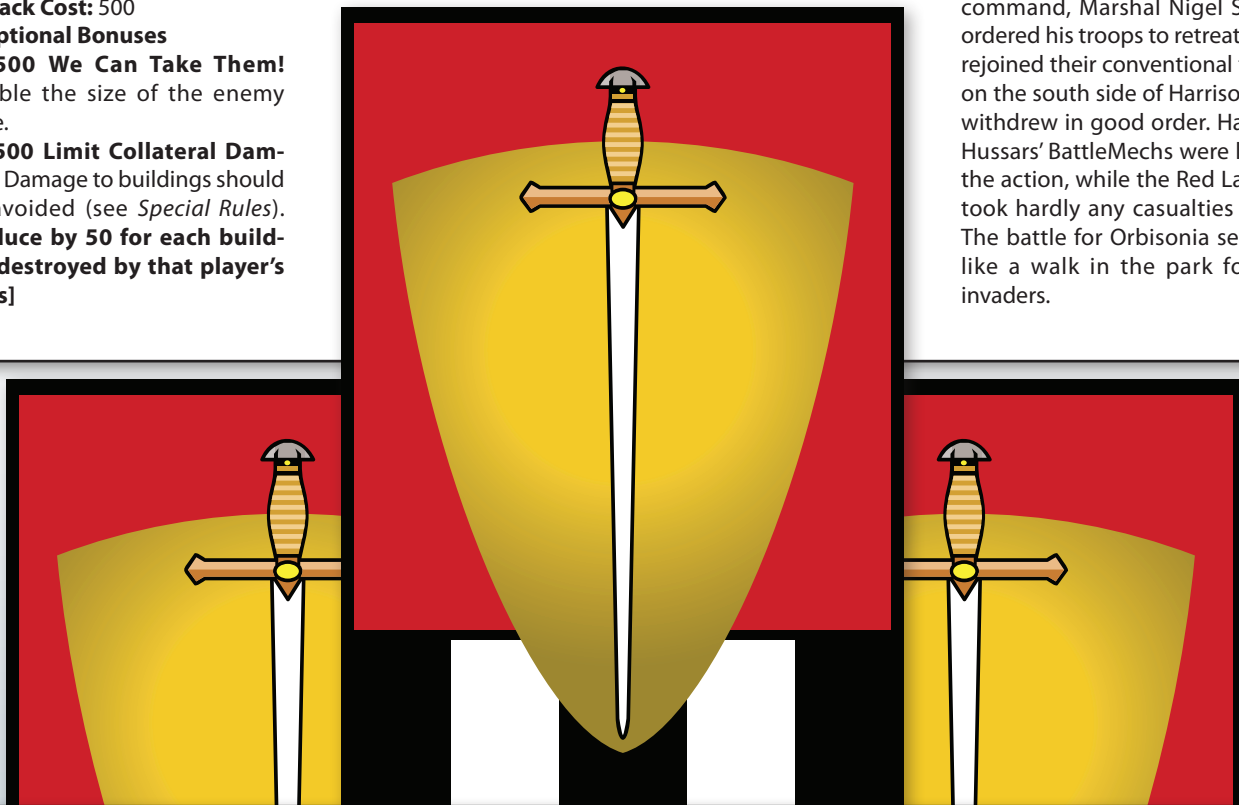



# CETI TWILIGHT

## SITUATION

Lancaster  
Orbisonia  
Federated Suns  
19 June 2828

The Ceti Hussars were completely unprepared for the Prefectorate Guard's arrival, having only just received word of the Capellan landings and their engagement with the planetary militia. The Hussars were regrouping their distant units from a training operation when sensors detected the Guard's dropping BattleMechs. Now the Hussars were spread out and facing the serious threat of piecemeal extermination.

## GAME SETUP

*Recommended Terrain:* Wilderness, Urban

Arrange the playing surface to have a mix of varying wilderness terrain on one end and urban terrain on the other, or select one mapsheet from the Urban column of the Orbisonia Terrain Table (p. 5) and one mapsheet from the Wilderness column and place them with their long edges touching. If using terrain, place buildings of various sizes and types throughout the urban portion of the map. The Defender's home edge is the urban edge; the Attacker's home edge is the opposite.

### Attacker

*Recommended Forces:* Prefectorate Guard

The Attacker's force is 100 percent of the Defender. The Attacker enters via their home edge on Turn 1.

### Defender

*Recommended Forces:* Second Ceti Hussars

The Defender deploys on the map prior to the start of play. Deployed units must be combined arms, integrating BattleMechs, vehicles, and foot infantry platoons (player may choose equal numbers of platoons of varying foot infantry types) at the company level. The Defender's units must be placed at least 12 hexes or 24" from their home edge.

## WARCHEST

**Track Cost:** 500

### Optional Bonuses

**+500 Too Many!** Double the size of the enemy force.

**+500 Decapitate.** Each side declares (and reveals to the opposing player) one BattleMech to be their regimental commander; the opposing side must destroy or cripple the commander's unit. If either side loses their commander, they suffer a -4 modifier to

all Initiative rolls for the remainder of the game. This modifier is removed if the other side's commander is destroyed, crippled, or exits the battlefield.

## OBJECTIVES

**1. Control the Field.** Control the battlefield at the end of the battle (by having more active units when players agree to end the battle). [750]

**2. Intel Source.** Capture at least one enemy for interrogation. This is accomplished by disabling or crippling an enemy unit before Turn 12, and keeping a friendly unit adjacent to it for the duration of the battle (to prevent its pilot or crew from escaping). [500]

**3. Kill or Be Killed.** Destroy enemy units. [100 per unit]

## SPECIAL RULES

The following rules are in effect for this track:

### Forced Withdrawal

Both sides are operating under *Forced Withdrawal* (see p. 258, TW or p. 27, AS).

## AFTERMATH

The Prefectorate Guards' surprise was not complete, but it was close to it. The Second Ceti Hussars could not hold against such overwhelming firepower; however, they stalled the Prefectorate Guard long enough for their command elements to evacuate Lancaster proper, but little longer than that. They abandoned their DropShips, supplies, and much of their support elements. The Prefectorate Guard slowed their pursuit to secure the Hussars' headquarters, allowing the Hussars to regroup in the wilderness, but without supplies to effect repairs. The Guard was confident of eradicating the Hussars if they could force them into open combat.



# HARRISON PRESS

## SITUATION

Harrison  
Orbisonia  
Federated Suns  
20 June 2828

The Red Lancers refused to ease up as they pursued the Fourteenth Avalon Hussars through Harrison. On the southern outskirts of the city, the Fourteenth rallied to meet the threat and buy time for their nearby headquarters to evacuate. The Lancers saw the prize and pushed even harder to reach it.

## GAME SETUP

*Recommended Terrain:* Urban, Wilderness

Arrange the playing surface to have a mix of varying wilderness terrain on one end and urban terrain on the other, or select one mapsheet from the Urban column of the Orbisonia Terrain Table (p. 5) and one mapsheet from the Wilderness column and place them with their long edges touching. If using terrain, place buildings of various sizes and types throughout the urban portion of the map. The Defender's home edge is the wilderness edge; the Attacker's home edge is the opposite.

### Attacker

*Recommended Forces:* Red Lancers

The Attacker's force is 100 percent of the Defender. The Attacker's units enter the map on Turn 1 via their home edge. Units which did not participate in "Paint the Town Red" must mark off damage in all locations except the head equal to one-tenth their armor rating in those locations, rounding down (infantry units must reduce their number of troops per platoon by one-tenth). Units present for that engagement will enter play in the condition in which they concluded that game; no repairs will be possible between battles.

### Defender

*Recommended Forces:* Fourteenth Avalon Hussars

The Defender's BattleMechs are placed on the map before Turn 1, within 4 hexes or 8" of the Attacker's home edge. Units which did not participate in "Paint the Town Red" must mark off damage in all locations except the head equal to one-fourth their armor rating in those locations, rounding down (infantry units must reduce their number of troops per platoon by one-fourth). Units present for that engagement will enter play in the condition in which they concluded that game; no repairs will be possible between battles. Non-BattleMech units may be placed across the playing surface at its mid-point, or within one hex of where the mapsheets are joined. Only one-quarter (rounding down) of these conventional forces may be placed as Hidden Units, due to lack of time to prepare concealing positions. The Defender must also include one Mobile HQ unit, which does not count toward the attacking force's size and must be deployed with the other conventional units at the middle of the playing surface.

## WARCHEST

**Track Cost:** 750

**Optional Bonuses**

**+500 Weight of Numbers.** Double the size of the enemy force.

**+500 Headhunting.** Each side declares (and reveals to the opposing player) one BattleMech to be their regimental commander; the opposing side must destroy or cripple the commander's unit. If either side loses their commander, they suffer a -4 modifier to all Initiative rolls for the remainder of the game. This modifier is removed if the other side's commander is destroyed, crippled, or exits the battlefield.

## OBJECTIVES

- 1. Now or Never.** Destroy enemy units. [50 per unit destroyed]
- 2. Stem the Tide.** Prevent enemy units from exiting via the Defender's home edge. [100 per unit]
- 3. Target of Opportunity.** The Attacker must destroy or cripple the Mobile HQ; the Defender must exit the Mobile HQ from the map via the Defender's home edge. [500]

## SPECIAL RULES

The following rules are in effect for this track:

### Forced Withdrawal

The Attacker is operating under *Forced Withdrawal* (see p. 258, *TW* or p. 27, *AS*). The Defender is not operating under *Forced Withdrawal* until the Mobile HQ exits via home edge or is destroyed or crippled.

### Moonless Night

This battle takes place at night; use the rules for *Moonless Night* (see p. 58, *TO* or pp. 92-95, *AS*).

## AFTERMATH

The Fourteenth Avalon Hussars narrowly escaped destruction outside Harrison. Their skirmish line held long enough for the Hussars headquarters section to slip into the wilderness, but it cost the command half their BattleMechs. The conventional elements were more fortunate, being further back from the line of battle. The Red Lancers, however, came through with very few losses. Rather than halting the attack and consolidating their hold on Harrison, they saw blood in the water, and the pursuit was on. However, by morning, word came that the Davion Assault Guards had arrived in-system and were burning hard for Orbisonia. The Chancellor called for all Capellan forces to withdraw to the Cretaceous Basin. It would be a long, difficult march for the heavy 'Mechs.



# TURNABOUT INTRUDERS

## SITUATION

Jackal Forest  
Orbisonia  
Federated Suns  
20 June 2828

The Prefectorate Guards received word of the Davion Assault Guards' imminent arrival while in hot pursuit of the Second Ceti Hussars in the wilderness outside Lancaster. New orders soon arrived to disengage and head overland to the rendezvous in the distant Cretaceous Basin. Though excellent combat 'Mechs, *Warhammers* and *Marauders* are sorry sprinters, and the Ceti Hussars were not content to let the Capellans simply turn and depart. Deep in the forest, the hunters had become the hunted.

## GAME SETUP

*Recommended Terrain:* Wilderness

Arrange the playing surface so that at least half is forested, or select two mapsheets from the Wilderness column of the Orbisonia Terrain Table (p. 5) and place them with their short edges touching. The map should be long and narrow with no roads, paved hexes, buildings, or other signs of civilization. The Defender chooses a home edge; the Attacker's home edge is the opposite edge.

### Attacker

*Recommended Forces:* Second Ceti Hussars

The Attacker's force is 300 percent of the Defender; one-third of the Attacker's units must be vehicles, and one-third must be infantry (player may choose any variety of foot infantry platoons). The Attacker enters via their home edge on Turn 1. Units which did not participate in "Ceti Twilight" must mark off damage in all locations except the head equal to one-third their armor rating in those locations, rounding down (infantry units must reduce their number of troops per platoon by one-fourth). Units present for that engagement will enter play in the condition in which they concluded that game; no repairs will be possible between battles.

### Defender

*Recommended Forces:* Prefectorate Guard

The Defender deploys within 4 hexes or 8" of the Attacker's home edge. Units which did not participate in "Ceti Twilight" must mark off damage in all locations except the head equal to one-fifth their armor rating in those locations, rounding down (infantry units must reduce their number of troops per platoon by one-fourth). Units present for that engagement will enter play in the condition in which they concluded that game; no repairs will be possible between battles. The Defender's force should consist of at least one company of BattleMechs, but the entirety of the Guard that survived prior tracks is available. This company includes two medium lances, each of which includes at least one *Hunchback* (from the available variants in the Random Assignment Table, p. 6) and one RFL-3N *Rifleman*. See *Special Rules* for these lances.

## WARCHEST

**Track Cost:** 500

### Optional Bonuses

**+1000 Wildfire.** A naturally-occurring forest fire is burning through the playing area (see p. 43, *TO* or p. 100, *AS*). The fire is contained to the half of the map with the Defender's home edge.

Assume Wind Force 1 toward the Defender's home edge, with no direction changes.

**+500 This Is the Pits.** The ground in this region is unstable. Fissures might open up under any unit at any time (see p. 93, *AS*, or use the fissure segment of the *Earthquake* rules, p. 55, *CO*). Roll for a fissure to open under any vehicle or BattleMech at the end of every Movement phase.

## OBJECTIVES

- 1. Thin Their Numbers.** Destroy or cripple enemy units. [100 per unit]
- 2. Cut Them Off (Attacker Only).** Prevent the Defender's units from exiting via their home edge. [100 per unit that does not escape]
- 3. Live to Fight Another Day (Defender Only).** Exit units off map via home edge. [100 per unit that escapes]
- 4. Make or Break.** The Defender must keep the Support Lances (see below) at the rear of the formation for the entire battle. If they break and run (per Forced Withdrawal rules), the Attacker completes this objective. [200 per lance]

## SPECIAL RULES

The following rules are in effect for this track:

### Forced Withdrawal

The Attacker is operating under *Forced Withdrawal* (see p. 258, *TW* or p. 27, *AS*). Only part of the Defender's force is operating under *Forced Withdrawal* (see *Supporting Lances*, below).

### Supporting Lances

The Defender's force includes two lances as described above. These lances are the rearguard for the *Marauders* and *Warhammers* and must be deployed at the rear (at least 1 hex or 2" away) of the Defender's force to start the battle. These units must remain at the rear of the formation as long as possible.

## AFTERMATH

The fighting in the Jackal Forest was savage, and while the Capellans fled, they were hardly broken. The Ceti Hussars pushed hard, but the Guard's well-organized retreat didn't turn into a rout, aside from a few rearguard lances which broke under fire. The remaining Capellans still possessed superior firepower, and simply adjusted their deployment accordingly.

# DEATH GRIP

## SITUATION

*Western Suburbs of Harrison*

*Orbisonia*

*Federated Suns*

*21 June 2828*

The Red Lancers surprised the Fourteenth Avalon Hussars by inexplicably stopping their advance and withdrawing from battle. The Hussars, never ones to let opportunity slip away, ignored their fatigue and damage, and struck at the retreating Capellans. Little did they know the lengths the Capellans would go to in their escape.

## GAME SETUP

*Recommended Terrain:* Urban, Wilderness

Arrange the playing surface to be twice as long as it is wide and represent urban terrain on one side, changing to forested terrain on the other; or select one mapsheet from the Urban column of the Orbisonia Terrain Table (p. 5) and one mapsheet from the Wilderness column and place them with their short edges touching. Place buildings of varying type and size on the urban side of the playing surface. The Defender's home edge is the short edge in the forested portion of the map; the Attacker's home edge is the opposite edge.

### Attacker

*Recommended Forces:* Fourteenth Avalon Hussars

The Attacker's force is 300 percent of the Defender. The Attacker's BattleMech units enter the map via their home edge on Turn 1. The Attacker's vehicle units are placed on the map along the Defender's home edge prior to Turn 1. At least two-thirds of the Attacker's force must be non-BattleMech units. Units which did not participate in previous tracks must mark off damage in all locations except the head equal to one-half their armor rating in those locations, rounding down; vehicle units must mark off damage equal to one-third their armor rating in all locations, rounding up. Units present during prior engagements will enter play in the condition in which they concluded those games; no repairs will be possible between battles.

### Defender

*Recommended Forces:* Red Lancers

The Defender deploys along the Attacker's home edge prior to the start of play. The Defender's forces should include at least one company of BattleMechs. Units which did not participate in prior tracks must mark off damage in all locations except the head equal to one-fourth their armor rating in those locations, rounding down. Units present during prior engagements will enter play in the condition in which they concluded those games; no repairs will be possible between battles.

## WARCHEST

**Track Cost:** 1000

**Optional Bonuses**

**+500 In the Dark.** This battle takes place at night (use *Moonless Night* rules; see p. 58, *TO* and pp. 92-95, *AS*).

**+500 Mismatch.** Double the size of the enemy force.

## OBJECTIVES

**1. Retreat (Defender Only).** Exit all units off the Defender's home edge before Turn 15. **[100 per unit]**

**2. Prevent Retreat (Attacker Only).** Prevent the Defender's units from exiting via their home edge before Turn 15. **[100 per unit]**

**3. Parting Shots.** Destroy or cripple enemy units. **[100 per unit destroyed/crippled]**

## SPECIAL RULES

The following rules are in effect for this track:

### Forced Withdrawal

At the beginning of the track, the Attacker is operating under *Forced Withdrawal* (see p. 258, *TW* or p. 27, *AS*). However, after any of the Attacker's units are destroyed by a chemical weapon attack, the Attacker's BattleMechs are no longer subject to *Forced Withdrawal*.

### Chemical Weapons

The Red Lancers have acquired missiles equipped with chemical warheads from Supply Depot 124KT. Every one of the Defender's BattleMechs equipped with LRMs or SRMs replaces one ton of ammo with these missiles; each ton is sufficient to fire chemical weapons from the launcher three times. Enemy units cannot be directly targeted; instead, the player using this ammo type must select a hex or point on the map. A standard attack roll is made; if unsuccessful, the weapon fails to explode and thus the attack is wasted. If the attack succeeds, chemical gas immediately disperses from the impact site, filling that hex and each adjacent hex or a region 6" in diameter. All non-BattleMech units within this area of effect, or which later pass through it, must immediately roll 2D6 to survive the gas, succeeding on an 11+. Units which fail this roll are considered destroyed. The area of effect lasts until the third End Phase after the gas is deployed; the gas does not expand beyond its initial area of effect.

## AFTERMATH

The Fourteenth Avalon Hussars thought they had the withdrawing Red Lancers contained after sending speedy hovercraft to cut off the Lancers' line of retreat—until the Capellans resorted to the use of chemical weapons. The Hussars' conventional units were devastated. The toxin cleared a path for the Lancers to escape, but the Hussars would never forgive such an attack—they demanded vengeance.



# WE MEET AGAIN

## SITUATION

*Edge of Cretaceous Basin*

*Orbisonia*

*Federated Suns*

*22 June 2828*

The remaining Capellan troops embarked on a cross-country forced march which took more than a day. Finally, the Cretaceous Basin was in sight, and the Red Lancers and Prefectorate Guard linked back up. But the Davion Assault Guards had dropped their troops on the heels of the fleeing Liao units, while the Second Ceti Hussars and rabid Fourteenth Avalon Hussars had no intention of allowing the Chancellor's retreat to be an easy one.

## GAME SETUP

*Recommended Terrain:* Wilderness, Moonscape

Arrange the playing surface so that half is forested wilderness and half is moonscape to represent the edge of the Cretaceous Basin, or select one mapsheet from the Wilderness column of the Orbisonia Terrain Table (p. 5) and one mapsheet from the Moonscape column and place them with their long edges touching. In the moonscape portion of the playing surface, place large, Level 10 obstacles throughout; these may be round columns occupying a small (1 hex or 2") footprint, or long walls creating a labyrinth. The Attacker and Defender alternate placing these obstacles until the Defender chooses to end the placement. The Attacker's home edge is the forested edge; the Defender's home edge is the moonscape edge.

### Attacker

*Recommended Forces:* Second Ceti Hussars, Fourteenth Avalon Hussars, Davion Assault Guards

The Attacker's force is 100 percent of the Defender. At least half of Attacker's force is from the two Hussars regiments. Hussars units enter the map via their home edge on Turn 1. Davion Assault Guards units enter via home edge on Turn 3. All Hussars units which did not participate in previous tracks must mark off damage in all locations (except the head) equal to two-thirds their armor rating in those locations, rounding down. Ceti Hussars infantry units which did not participate in prior tracks must reduce the number of troops per platoon by one-half. Units present during prior engagements will enter play in the condition in which they concluded those games; no repairs will be possible between battles.

### Defender

*Recommended Forces:* Red Lancers, Prefectorate Guard

The Defender's units are placed on the map along Attacker's home edge prior to Turn 1. Defender includes at least one company of BattleMechs from each command. Reduce armor of all units from both commands by one-third (round down) in all locations for units not played in prior tracks; units which did appear in prior tracks should be in the condition at the end of their last combat appearance.

## WARCHEST

**Track Cost:** 1000

### Optional Bonuses

**+500 Baptism of Hate.** The battle takes place during a torrential downpour (see p. 59, *TO* or p. 95, *AS*).

**+500 The Flood.** Double the size of the enemy force.

## OBJECTIVES

- 1. Limit Losses (Defender Only).** Exit units via Defender's home edge. [100 per unit]
- 2. Cut Them Off (Attacker Only).** Prevent the Defender's units from exiting via their home edge. [100 per unit]
- 3. Reap the Harvest.** Destroy/cripple enemy units. [50 per unit]

## SPECIAL RULES

The following rules are in effect for this track:

### Forced Withdrawal

The Attacker's forces are operating under *Forced Withdrawal* (see p. 258, *TW* or p. 27, *AS*), with the exception of Fourteenth Avalon Hussars units.

## AFTERMATH

The invaders had fared exceptionally well in their prior engagements, but the Davion Assault Guards took a toll on the retreating Capellans. Even so, the majority of the Liao troops slipped away while others held the Davion forces back. But the Chancellor's forces weren't out of danger yet, and their DropShips were still some distance away. The Davion regiments regrouped quickly and renewed their pursuit.



# ILSA'S

# LAST STAND

## SITUATION

*Cretaceous Basin  
Orbisonia  
Federated Suns  
24 June 2828*

The Chancellor issued orders for all her troops to retreat with full haste—they were not to engage the enemy, only to flee for their DropShips. Troops streamed to their DropShips through the day on 23 June, but as night fell, too many more still struggled to escape the Davion forces. In the pre-dawn hours, Ilsa and her personal guard, untouched by the earlier battles, elected to hold the way open and stop the Davion forces from cutting the retreating troops to pieces—they vowed to hold, no matter the cost.

## GAME SETUP

*Recommended Terrain:* Open Terrain, Moonscape

Arrange a rectangular playing surface, or select one mapsheet from the Wilderness column of the Orbisonia Terrain Table (p. 5) and one mapsheet from the Moonscape column and place them with their short edges touching. The Defender chooses one short edge as their home edge; the opposite edge is the Attacker's home edge. Arrange terrain to create a choke point with an opening 13 hexes or 26" wide. The terrain on either side should be high enough to prevent any unit from jumping over it. Additional obstacles should be placed by the Defender in the first quarter of the playing surface, beginning at the Attacker's home edge. Terrain on the other side of the choke point should be clear.

### Attacker

*Recommended Forces:* Fourteenth Avalon Hussars, Second Ceti Hussars, Davion Assault Guards

All units enter via the Attacker's home edge. Surviving Avalon and Ceti Hussars 'Mechs, maintaining all damage from prior battles, may be used in this track. One lance of Hussars may move onto the map starting on Turn 1, and one additional lance per turn thereafter. The Davion Assault Guards may move one lance onto the map per turn beginning on Turn 5. The Attacker's force is composed of Avalon and Ceti Hussars units equal to the number of Red Lancer and Prefectorate Guard units in the Defender's force, and Davion Assault Guards equal to the number of Chancellor's Personal Guard units. All Hussars units which did not participate in previous tracks must mark off damage in all locations except the head equal to two-thirds their armor rating in those locations, rounding down. Units present during prior engagements will enter play in the condition in which they concluded those games; no repairs will be possible between battles.

### Defender

*Recommended Forces:* Red Lancers, Prefectorate Guard, Chancellor's Personal Guard

Red Lancers and Prefectorate Guard BattleMechs are placed on the Attacker's home edge before Turn 1. All units that will not fit on



the map edge must enter the map via the Attacker's home edge on Turn 1. These units all operate under Forced Withdrawal and may only exit the map via Defender's home edge. The Chancellor's

Personal Guard is placed in the opening of the choke point; they will block enemy units from passing but allow allied units to pass. The Defender must note which unit represents Chancellor Ilsa Liao, but need not reveal that unit to the Attacker. All Red Lancers and Prefectorate Guard units which did not participate in previous tracks must mark off damage in all locations except the head equal to half their armor rating in those locations, rounding down. Units present during prior engagements will enter play in the condition in which they concluded those games; no repairs will be possible between battles.

## WARCHEST

**Track Cost:** 1000

### Optional Bonuses

**+500 Stop the Tide?** Increase the number of enemy's Guard units by half. (Applies to Davion Assault Guards or Chancellor's Personal Guard only.)

**+500 Dust to Dust.** Dust clouds obscure targeting; reduce all weapon ranges/brackets by half (rounding down).

## OBJECTIVES

**1. Hounds (Attacker Only).** Destroy/cripple fleeing enemy units. [100 per unit]

**2. Foxes (Defender Only).** Exit Red Lancer and Prefectorate Guard units off the Defender's home edge. [100 per unit]

**3. Guard on Guard.** Destroy/cripple all Davion Assault Guards (Defender only) or Chancellor's Personal Guard units (Attacker only). [200 per unit]

## SPECIAL RULES

The following rules are in effect for this track:



**Night Turns to Day**

This battle begins at night (see rules for *Moonless Night*, p. 58, *TO* or p. 95, *AS*). Beginning on Turn 6, use the rules for *Dawn* (see p. 58, *TO* or p. 92, *AS*).

**Forced Withdrawal**

The Attacker is operating under *Forced Withdrawal* (see p. 258, *TW* or p. 27, *AS*). The Defender's Red Lancers and Prefectorate Guard units are also operating under *Forced Withdrawal*. However, the Chancellor and her personal guard are not.

**Inspiration**

Starting in Turn 5, the Defender may roll 2D6 in each End Phase during which Ilsa is still alive. On a roll of 8+, she has given her rallying speech and inspired her personal guard. These MechWarriors may choose one additional SPA from any source for the remainder of the battle. They also ignore heat effects to targeting and potential shutdown (save automatic shutdown). The speech may only be given one time, so no additional rolls take place after a successful roll.

**AFTERMATH**

Chancellor Ilsa Liao sold her life dearly, as more than 80 percent of the Red Lancers and Prefectorate Guard BattleMechs reached their DropShips and escaped Orbisonia. However, she and her entire personal guard were killed delaying the Davion Assault Guards, making her the first Chancellor to die in battle. Her exhortations over an open comm channel not only steeled her fellow rearguard in the face of certain death, but also bolstered the morale of those whose retreat she was protecting. The Red Lancers were so inspired by her final words they became known as the Red Heart Guard, striving to embody her sentiment and earn the sacrifice she made for them. The Second Succession War would not proceed as Ilsa had hoped with her surprise invasion. While she disrupted the large-scale invasion First Prince Paul Davion was planning, his ensuing scaled-down efforts were largely successful thanks to the heavy losses Ilsa's invading forces suffered. The worlds he went on to seize remained in Davion hands for generations to come.

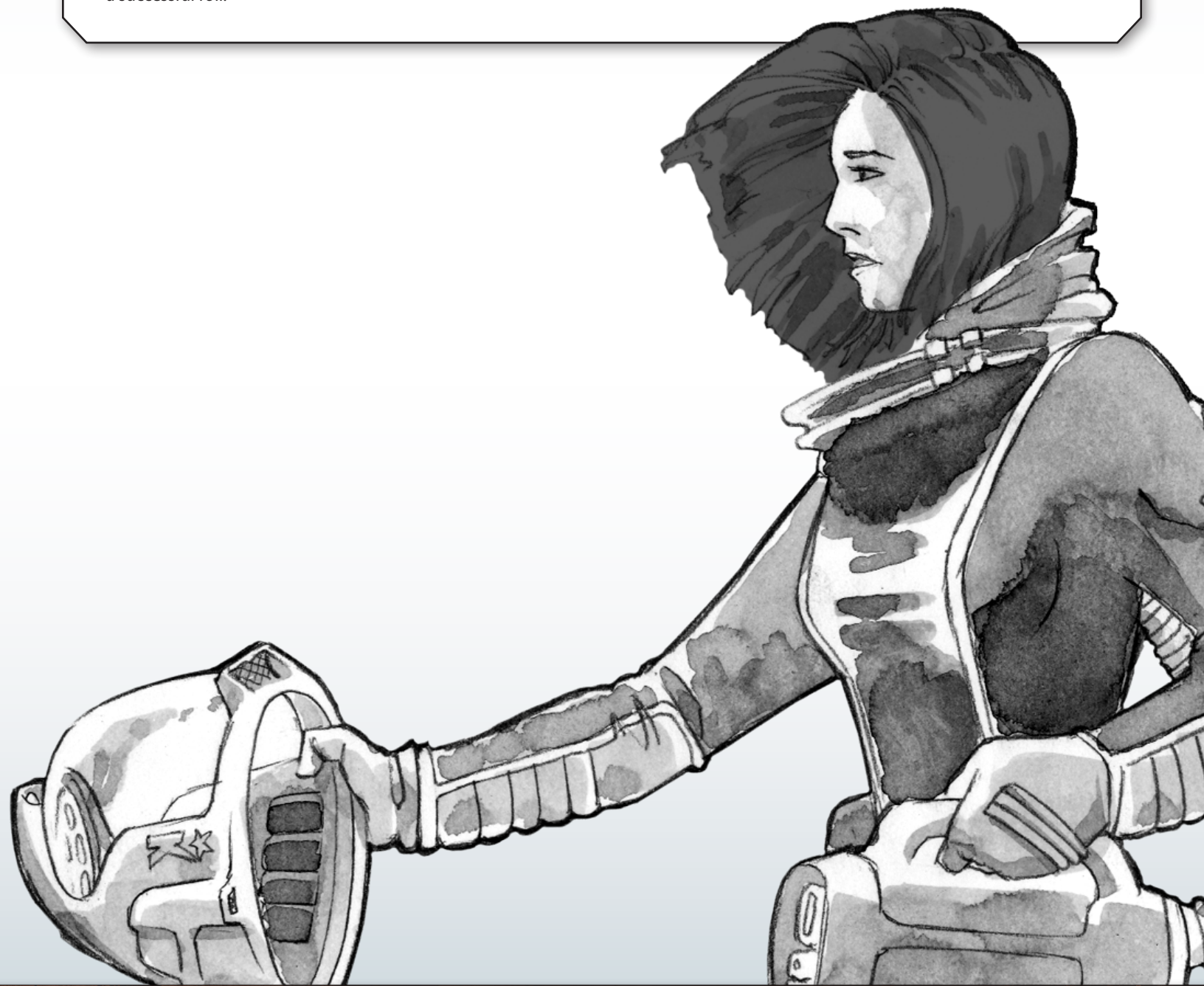

# THE RED HEART

**Cretaceous Basin**

**Orbisonia**

**Federated Suns**

**24 June 2828**

The ancient ocean floor had been dry since dinosaurs walked the surface of Terra. Massive fossilized coral monoliths loomed over the heads of the BattleMechs waging war in thoroughfares formed through millennia of erosion. The light and medium 'Mechs of the Avalon and Ceti Hussars darted between the heavier 'Mechs of the fleeing Red Lancers and Prefectorate Guard, delaying their retreat. The slower 'Mechs of the Davion Assault Guards were coming, doom incarnate.

Chancellor Ilsa Liao absorbed the changing tableau as it swam before her. The supreme ruler of the Capellan Confederation had erred on a truly grand scale—the simple diversionary effort she envisaged had become a rout. Instead of preventing the Davion forces on Orbisonia from reinforcing their beleaguered comrades on Chesterton, reinforcements came to Orbisonia.

She calmly directed a stream of explosive shells from her *Marauder's* autocannon, taking the leg off an enemy 'Mech. The Ceti Hussars *Phoenix Hawk* cartwheeled along the basin surface, smashing hard into a coral column. It did not stir. Ilsa was too exhausted to smile. Instead, she pivoted on her left foot, stepping back and clearing a space for another lance of Prefectorate Guard 'Mechs to file past. A *Warhammer* shouldered her aside in haste, but there was no apology, no recrimination. No insult was either intended or taken. She knew the MechWarrior was simply following her orders. Retreat at all costs. Do not slow, do not stop, do not engage the enemy. Flee for safe haven in the protective umbrella of the Capellan DropShips. She glanced at the compressed rear view on her screen. The symmetric lumps eclipsing even the gargantuan coral formations called to her.

She resisted the siren call. Her duty was to save those she had endangered with her own shortsightedness. Ilsa was not alone: the twelve BattleMechs of her personal guard stood with her. She had ordered them to withdraw, too. Captain Leticia Sanchez mistuned her comm system and replied amidst the static, "Say again, say again, did not copy. Comms are being jammed." Ilsa loved her for that loyalty and selflessness. The thirteen Capellans had not yielded a centimeter since taking position in a bottleneck between two skyscraping towers of prehistoric death. The labyrinth of obstacles terminated at these coral gateposts, leaving open ground beyond, over which retreating 'Mechs streamed unimpeded.

The fast 'Mechs of the two Hussars regiments were ideal for reconnaissance and pursuit, but they dared not assault the line of *Warhammers* and *Marauders* arrayed along the breadth of the narrow pass. Any who were fixed on their quarry joined others foolish enough to try to breach the Chancellor's line in death. Heaps of enemy 'Mechs had accumulated over a wide stretch. The legacy of warfare was writ large on the blasted landscape, the carcasses of modern combat fouling footing and forming new obstacles for those yet to come.

A wave of dust blew past her cockpit from the rear. A tremor shook her *Marauder* just before the sound of enormous engines heralded the liftoff of another of her DropShips. She sighed, knowing another group was safely away. Her relief was short-lived.

Through the dust cloud, Ilsa spotted a flash of royal blue broken by vertical red and white stripes. A chill ran down her spine. The Assault Guards had arrived.

They were the most feared formation of the Federated Suns military. Every BattleMech an assault-class behemoth. Every MechWarrior among the best of the best of any nation. Their presence lent an indefinable note to the feel of the battle. Her loyal troops coaxed additional speed from their fleeing 'Mechs. The enemy Hussars found greater boldness,

slashing closer and closer to the coral gate, daring the rearguard to break formation. She destroyed a pair of *Wasps* in Avalon Hussars colors, which disappeared into the mounds of shattered 'Mechs.

She wanted to flee. The specters of Davion indomitability instilled fear even to the dust of shattered coral. A fell wind blew the basin clear, revealed the serried ranks of encroaching death. She thought of her parents, whom she had never truly known, and of her mentor, Sandol Quinn. What might they think of her fear of the enemy? She steeled herself. If she were afraid, so too would her guardians be.

Another company of Red Lancers crossed the gate and fled apace. She had led them here. This was her doing. Even those who survived might be forever broken by this defeat. She knew what she had to do.

Ilsa toggled her comm system, selecting the allied open channel. "Long ago on Terra, an ancient king had his throne placed on the seashore. He commanded the incoming tide to halt. However, as he had known it would, the tide rose in defiance of his futile orders, soaking him to the bone in full view of his court. He stood tall among them and announced, 'See the power of a king? There is none who can counter the wishes of He that made Heaven, Earth, and Sea! No king of ancient Terra could stop the tides. But we are no longer bound to Terra! Nature has been conquered on every world of the Inner Sphere and beyond!' She thrust out the left arm pod of her *Marauder* towards the advancing Davion Guard. "See, now, the tide approaches! This coral gate is the shoreline! King Cnut failed to compel the tide to stop! We shall be more persuasive! *This* is the Red Line! They shall not cross it while we yet live! Show them how real warriors fight! Show them your hearts! For we are the beating red heart of the Confederation! None shall pass while the Red Heart beats on! Here we stand! And here they die!"

So saying, she leveled both arms at an *Atlas* striding forward at the limit of her weapons' effective range. Ilsa held still for an instant, steadying her aim against the pounding of her heart. She fired. Two coruscating blue bolts sped into the distance. The *Atlas* staggered, its death's-head canopy sundered by particles moving at relativistic speeds. It crashed to the stone underfoot, another casualty of the pursuit.

Ilsa wanted to keep shouting, but she knew she didn't need to. She could see the tail end of the retreat. Few were left and those who struggled on were being systematically cut down. The last stragglers passed the coral gate. They were heavily damaged and could not cross the basin before being caught.

She had a choice. Join the retreat, or stand and fight. A glance into the rear view made the choice for her. The stragglers were tens of minutes from reaching the DropShips. If the rearguard left the gateway, the Hussars would further hamstring the escapees. They would all be doomed. There was no real choice after all.

She stopped firing for a moment and looked out her canopy windows. First left, then right. She took in the moment. The primitive beauty of the landscape, the settling dust from another DropShip lifting off, the searing light from her allies' lasers, the curling contrails from their missiles, the chugging of autocannon firing, the flashes off casings as they pinwheeled to the heaps on the ground.

Ilsa Liao, Chancellor of the Confederation, was at peace. She found it in the hell of war. And she knew she could never leave it. This was the end of her song. She would voice as many verses as she could before the advancing tide finally reached her.

She looked forward to meeting old King Cnut, that she might teach him the error of his ways.

The Davion Guards closed in. They were implacable, irresistible, unstoppable.







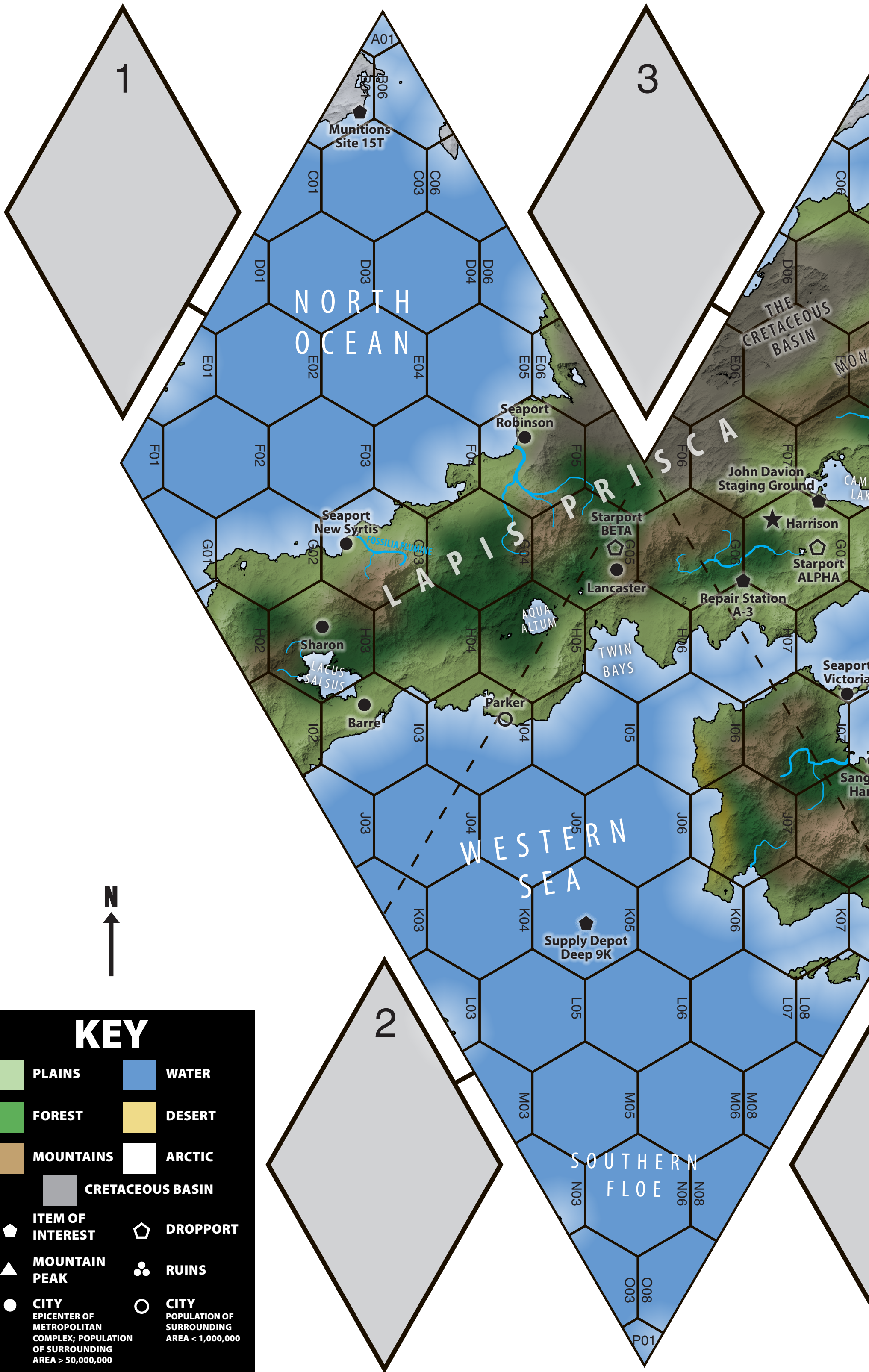





But for thirty-eight minutes, the tide was stopped.

Then it rolled over, in impotent fury, for there was no more quarry to chase.





# KEY

- |   |   |   |   |
|---|---|---|---|
|   | <b>PLAINS</b>   |  | <b>WATER</b>  |
|   | <b>FOREST</b>   |  | <b>DESERT</b>   |
|   | <b>MOUNTAINS</b>  |  | <b>ARCTIC</b>   |
|  | <b>CRETACEOUS BASIN</b>   |   | <b>ITEM OF INTEREST</b>                                   |
|   | <b>MOUNTAIN PEAK</b>  |  | <b>DROPPORT</b>   |
|   | <b>CITY</b><br>EPICENTER OF METROPOLITAN COMPLEX; POPULATION OF SURROUNDING AREA > 50,000,000 |  | <b>RUINS</b>  |
|   |   |  | <b>CITY</b><br>POPULATION OF SURROUNDING AREA < 1,000,000 |





5

7

NORTH  
OCEAN

SANGUINE  
SEA

M E T A M

PACIFIC  
EXPANSE

6

4

VULCAN'S FORGE

SOUTHERN  
FLOE

A01  
B11  
B06  
Nix  
Starport 18  
C17  
C08  
D08  
D11  
D09  
E09  
E11

A01  
B11  
B16  
Supply Station PD8  
C11  
C13  
C16  
D13  
D14  
D16

Pittstown  
Seaport New Avalon  
Supply Depot 51BK  
DIRA NIMUE  
Armstrong  
E11  
E10  
F09  
G08  
G09  
H08  
H09  
H10

Slippery Rock  
F11  
F12  
G11  
H11  
H12

DRAGONSH  
HEAD  
PENINSULA  
Altoona  
G12  
G13  
G14

Staging Ground Sandoval  
Starport 17  
Crimson Coast  
J10  
J11  
K08  
K09  
K10

'Mechus Hospitium  
AUREA FLUMINA  
L11  
L12  
L13

Storage Depot 49EM  
LACUS TEMERE  
Minima Saxa  
J12  
J13  
J14  
K13  
K14

THE LABYRINTH  
Supply Depot 44JR  
I15  
J15  
J16

Storage Depot 37SP  
Starport 19  
N08  
M08  
M10  
M13  
N11  
N13  
O13  
O18  
P01

Storage Depot 198LR  
N13  
N11  
O13  
O18  
P01

L13  
L15  
L16  
M13  
M15  
M18

L13  
L15  
L16  
M13  
M15  
M18  
N13  
N16  
N18  
O13  
O18  
P01







